

We believe in empowering companies with options to grow their business on their terms, not ours.

Melt Mate® Part Nos. KG1201 & KG12022

## Melt Mate® Adhesive Dispenser

The Melt Mate® is a durable all electric hot melt applicator system that is perfect for both packaging and product assembly. The system is designed for either 120V or 240V in order to accommodate customer needs. The glue system provides an option that is economical compared to tape, cold glue, metal fasteners, and other more expensive packaging methods. The tank is coated with a non-stick surface and generously holds 14 pounds of adhesive, which outsizes comparable brands. The larger tank allows for less time refilling. The Melt Mate® gives the user flexibility in that it can be utilized for small handgun operations or medium automatic operations and is designed with two channels for two hoses/applicators.



The Melt Mate® circuitry was designed for user ease. After installation of hose(s) and applicator(s), turn on and program the tank and hose/head channels. Programming is simple and easy to follow. The USB port allows for a data log download that lists recorded fault information and reflects changes to the programming. Pump can actually be toggled to the on position prior to ready. And once ready is established, if pump switch had been toggled, pump will start turning.

A 24/7 clock gives the flexibility of programming on/off times. This allows the tank to heat to set point before shift start up, reduces degradation of adhesive by not continuously heating when not in use, and extends the life of the tank by not heating continuously when not in use. This feature also helps reduce energy usage, which saves money.

### Features:

- Operating temp: 100°F - 450°F
- Tank Capacity: 14 pounds
- Melt Rate: 16 pounds per hour
- Pump Rate: 64 pounds per hour
- Controls: 24/7 Programmable clock
- Dimensions: 12"W x 25H x 18.5D



[www.keystoneparts.com](http://www.keystoneparts.com) For more information or technical support,  
[sales@keystoneparts.com](mailto:sales@keystoneparts.com) please contact the Keystone Team:

140 Manufacturers Court 800.235.8090 770.586.5990  
Winder, GA 30680

Keystone Industries, Inc. is not affiliated in any manner with Nordson®, ITW®, Slautterback®, Valco/Melton® or Graco®.

# Specializing in Hot Melts Parts & Systems

We believe in empowering companies with options to grow their business on their terms, not ours.

Melt Mate® Part Nos. KG1201 & KG12022

## Benefits:

- **Lightweight:** Easily moved at 48lbs (dry wt)
- **Quick Resolution:** USB port for downloading faults
- **Optional Voltage:** 120V or 240V
- **Large Reservoir:** More adhesive to support 2 applicators
- **Startup clock:** Program start up time/production ready
- **Consistent flow:** Gear pump provides steady glue flow

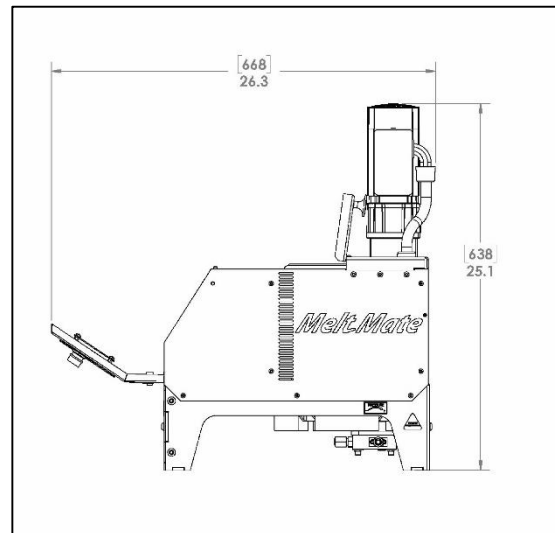
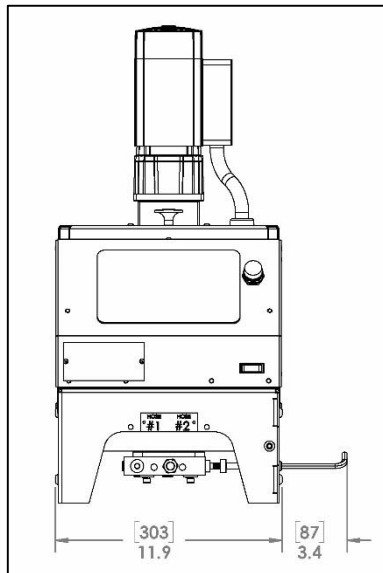

[CALL NOW FOR A QUOTE](#)



[www.keystoneparts.com](http://www.keystoneparts.com)  
[sales@keystoneparts.com](mailto:sales@keystoneparts.com)

For more information or technical support,  
please contact the Keystone Team:

140 Manufacturers Court  
Winder, GA 30680

800.235.8090

770.586.5990

Keystone Industries, Inc. is not affiliated in any manner with Nordson®, ITW®, Slautterback®, Valco/Melton® or Graco®.